

RAINGEAR

2 Speed Switch With Washer

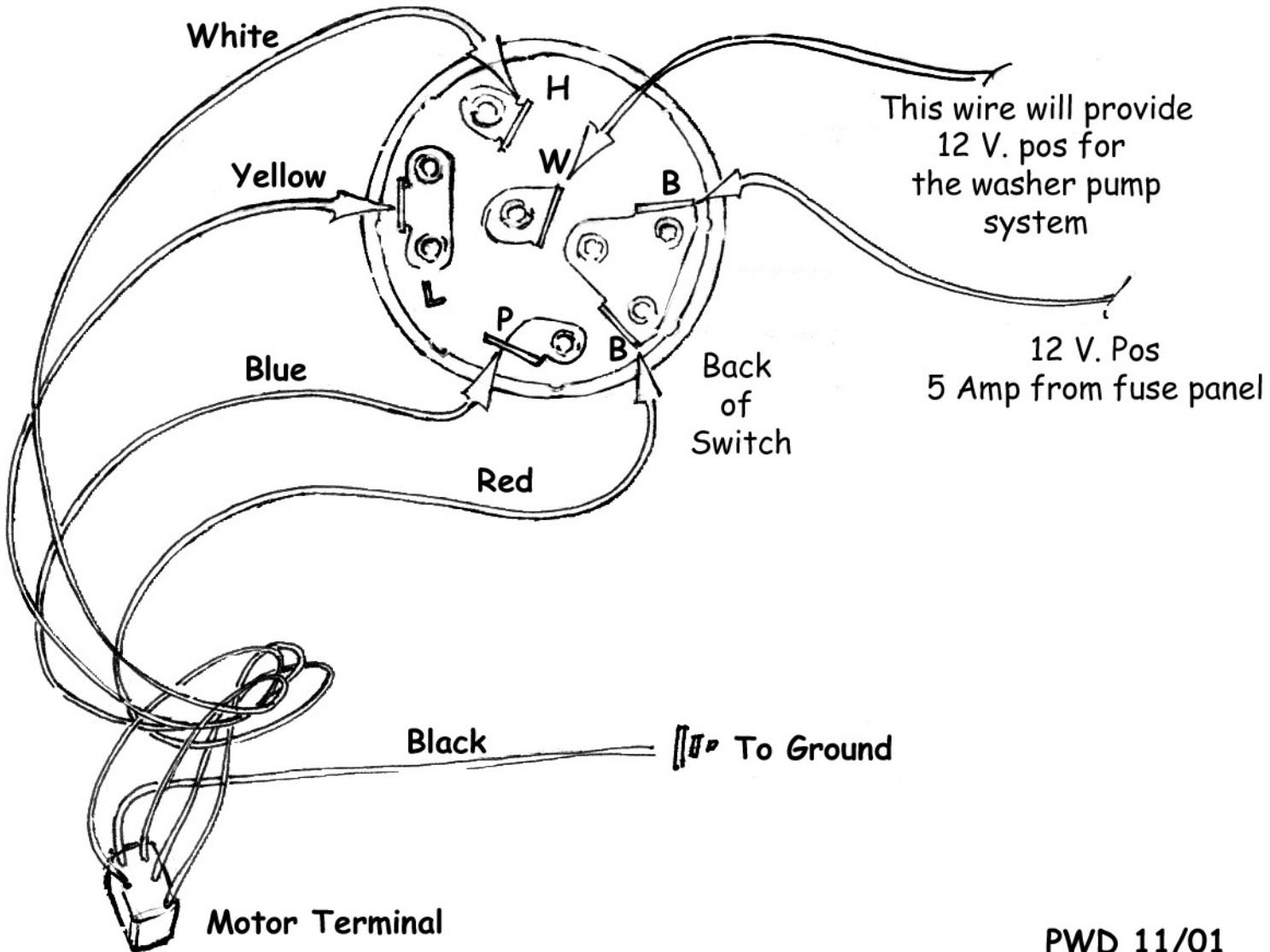
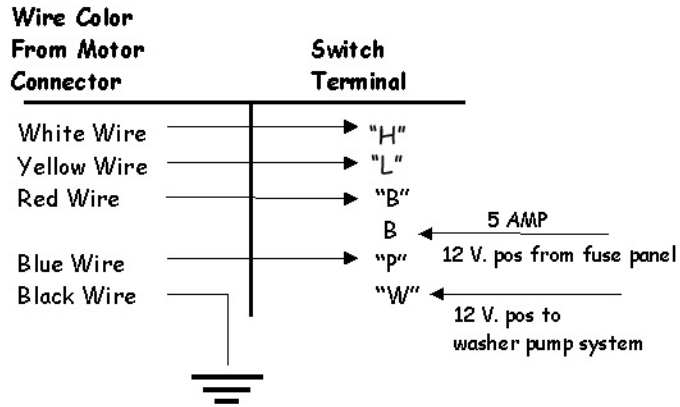

Wiring notes:

The diagram on the previous page shows how to wire the supplied wiring harness to the switch.

Plug the motor terminal end of the harness to the plug on the motor (it only connects one way). Connect the wires in the harness to the switch as shown, carefully matching each colored wire to the correct terminal on the switch.

If your wiper motor doesn't operate correctly (or not at all), first double-check your wiring of the switch as per the diagram.

Make sure you have 12 volts on the wire coming from your fuse panel. If you are using our delay switch note that it cannot be tested with just a battery charger! You must use a fully charged battery.

Make sure the black ground wire(s) is connected to a good, clean ground on the body. The ground wires should be contacting bare metal. Electricity doesn't flow well through paint.

If the switch is wired correctly, you are getting power, the black wire(s) is properly grounded and the motor still doesn't operate correctly, please call us on the phone and we will help you troubleshoot the problem.

Our phone number is: 360-385-5493, Mon-Fri 9a-4p Pacific Time.

A final note: The colors of the wires coming out of the motor to the plug and the colors of the wires in the supplied wiring harness DO NOT match up! If your motor doesn't work, please do not cut off the plug on the motor and attempt to connect the motor wires directly to the switch. This simply will not work.