

RAINGEAR

1957 Chevrolet

GETTING STARTED: SOME RECOMMENDATIONS PLEASE TRY OUR WAY FIRST!

Designer's Note: The Pacific Western Design wiper system you have purchased is complex and will require patient fitting. At times four hands are better than two, and two heads better than one.

Note: This system is designed with built in adjustments to fit in your car. If, as you are installing it, you think that you need to modify the parts supplied (except as noted), you are doing something wrong. Please reread the instructions or call us (1-360-385-5493) before proceeding. For technical questions, etc., please contact us directly! Your dealer does not stock spare parts and is unlikely to be able to troubleshoot problems.

Please familiarize yourself with the drawings and instructions that are included.

Note that the kit does not include the outside chrome escutcheons, (trim bezels) which cover the pivot shafts in the cowl. These escutcheons include the washer nozzles, which often need to be replaced. Pacific Western Design stocks the large size escutcheon assemblies for your 57 Chevy. See price list.

•First: DISCONNECT YOUR BATTERY•

You will be working under the dash in the area of your vehicle that contains the greatest concentration of electrical wiring.

- Remove the radio and glove box.
- It is easier to install this wiper system if you first remove the instrument panel.

Remove:

- The horn ring and steering wheel
- The turn signal lever and turn signal assembly (pull the signal housing aft and over the steering shaft)
- Remove the turn signal housing securing ring
- Remove the shift lever pin and shift lever
- Remove the shift lever ring from the column

The instrument panel is held in with four screws accessible from the outside of the dash and two 3/8" hex nuts accessible from inside the dash above the steering column. Be careful that you do not scratch the dash as you remove the panel.

- Reach in and unclip the big wire harness. This will allow the instrument panel to come away and make room for the new wiper system.
- Extra access can be gained by removing the clock, although it is not absolutely required.

NEXT:

- Remove the wiper control knob and cable from the dash. Save the knob and plastic information bezel for use with the new system.
- Remove your wiper arms and blades.

Dismantle the original wiper system:

- Remove the escutcheons from the pivot shafts.

- Remove the original pivot shafts from inside the car by removing the nuts that attach them to the cowl anchor brackets. (These anchor bracket locations will be used to mount the *Pacific Western Design* bridge assembly to the car - use care not to damage the studs.)
- Remove the stock wiper motor control cable from the wiper motor and push the cable through the firewall into the interior of the car.
- Remove the wiper motor and the center spool from the firewall.

Those of you who wish to retain the original appearance of the car may want to return the motor to the original location on the firewall after the Pacific Western Design system is installed and operational. A block-off plate is included if you would like to cover the hole in the firewall.

•PRE-ASSEMBLY•

- Refer to Figures 1,2,2A,2B and 4. Note that we now use a 1.72 " long spacer between the 5/8 "-24 hex nut and aluminum grommet ring (not shown on drawing 4), so that the hex nut can be tightened from outside the car. Pre-assemble the bridge and left hand drive unit on the bench so you understand how it fits in the car. **Please don't attempt installation in your car without this step because doing so will ultimately cost you time and aggravation!**
- Assemble the five-piece bridge assembly making sure that you orient the carriage bolts according to figure 2.
- Tighten the carriage bolts in the bridge ends. Then loosen these 4 bolts.
- Add the left and right hand mounting plates.
- Tighten then loosen the carriage bolts so that they also seat in the mounting plates. The four spacers (washers) shown on each end are for adjusting the bridge in the car and some or all may be used at the time of final fit.
- Install the two large rubber grommets in the left and right bridge ends.
- Install the two aluminum grommet spacers in the bridge, making sure that their orientation is as shown in figure 2B
- Install the right-hand pivot shaft and run the 5/8"-24 hex nut down against the 1.72" spacer and grommet ring.

Note that it has a rotation stop of square metal with a right angle bend attached so that it is possible to tighten the nut. The rotation stop tab fits into the slot of the RH bridge half.

- See figure 2. Install the left hand drive unit on the bridge by inserting the pivot shaft through the grommet, run down the 5/8-24 hex nut against the aluminum spacer and secure with a 1/4-20 carriage bolt and two washers as shown.
- Add the motor brace to the left hand drive unit as shown.

You now have the assembly as it will be correctly configured in your car with the carriage bolts seated so you can see how it will need to be installed in areas where you will not always have a clear view or working space.

- Remove the left-hand drive unit from the bridge.

IMPORTANT: *Tape the two washers that are used to space the left hand drive unit to the left end of the bridge (with the bolt hole clear for reinstallation of the bolt) so that when you reinstall the drive unit on the bridge while working under the dash the washers will not drop off the bolt. See figure 2A.*

- Remove the right and left mounting plates and the left bridge half from the bridge spanner.

•PRELIMINARY INSTALLATION and ADJUSTMENT of BRIDGE•

We advise that you put protective tape on the edges of the cowl pivot shaft openings so you do not scratch the paint from these areas while you are adjusting the fit of the bridge assembly. The bridge assembly determines the geometry of the system. The goal of the installation is to “float” the bridge and pivot post assembly into the cowl openings so that they are evenly spaced.

- Install the left and right hand mounting plates to the cowl mounting studs using the large 3/16 fender washers and 10-24 self-locking nuts. Snug but do not tighten at this time.
- Assemble the right hand bridge end to the bridge spanner.
- Raise the right hand bridge into the vehicle with the pivot shaft pointed forward and the bridge spanner forward of the defroster ducts and attach the far right slotted hole on the carriage bolt of the right hand mounting plate using a flat washer and ¼” nut.
- Similarly, attach the left hand bridge half (without the drive assembly) and attach the bridge ends together at the two studs on the bridge spanner.
- Shift the bridge assembly right and left until the right hand pivot shaft is centered equally.
- Add or subtract flat washers between the bridge and mounting plate until the outside chrome escutcheon slips onto the pivot shaft as easily as possible. See figure 4 for correct spacing.
- Try using the up and down spacing on the right side for the left side. Generally this works. If not you can repeat the procedure on the left side using the right hand pivot shaft.
- The bridge assembly should now be adjusted right, left, up and down.
- Snug, **but do not tighten**, at this time.

•FINAL ASSEMBLY•

1. Loosen the ¼” nuts on the mounting plates holding the bridge in place.
2. Disassemble the left-hand bridge end from the left hand mounting plate and spanner, and leave the bridge end loose where it lays.
3. Confirm that the two washers are taped to the tap on the drive assembly. See figure 2A.
4. **You should plug in the motor wiring harness into the wiper motor connector block at this time, as it is very difficult to do later when the system is assembled.**
5. Raise the pivot shaft end of the left hand drive assembly up (staying to the left of the steering column dash braces and/or clutch return spring) and place in the left hand bridge end. Insert the ¼” bolt on the bridge through the washers on the locator tab and reattach to the bridge assembly.
6. Add the 1.72” aluminum spacer and 5/8”-24 hex nut.
7. Reattach the left hand bridge and drive assembly to the mounting plates.
8. Pre-assemble the right and left links using care to orient the bushings correctly using the longer of the two sets of holes. See Figures 5 and 6. Make absolutely certain that the bushing is oriented correctly in the link half. The bushing is installable either way but there is only one correct orientation. They are a very tight fit. The pre-assembled cross link will pass into the dash opening, but it will fit only one way. The link bushings need to ride freely on the drive pins.
9. **Make certain the right hand pivot shaft lever is pointed up. The lever will operate between the 10 o’clock and 2 o’clock quadrant. If it is anywhere in the vicinity of the 8 to 4 o’clock quadrant, it will run backwards and scrape a lot of paint off of your hood!**

10. Secure the cross link to the pin "D" of the left hand drive and the pin in the right hand lever with the special thin washer and the j-clip. You can use a ¼" open ended wrench to push and slide the clip in place. Pay attention to how you do the right hand side, because the left hand side is more difficult to see.
11. Make certain that everything is secure and tight.
12. Install escutcheons. GM used body putty (dum-dum) as a weather seal. Note that the squirter tubes on some escutcheons may hit the 1.72 spacer on some installations. Gently bend the tubes or notch the spacers for clearance. We stock our own "large size" 1957 Escutcheons which correctly fit the large cowl openings. See price list.

•SWITCH•

Note that the intermittent switch must have the black wire securely grounded to function. This unit will not function if the car body is not grounded and you CANNOT use a battery charger to test the system.

- Pre-wire the windshield washer pump (if used) at this time.
- Install the switch in the dash using the original bezel and knob removed from your original switch. Connect the red power lead to a 5 amp fused source controlled by the ignition switch. **You cannot use a battery charger to test the system.**
- Route the instrument cluster wire bundle through a wire clamp and attach it to the hole at the top of the left -hand drive assembly.
- Tie or tape heater, clock and speaker wires away from the long link.
- Test electrical operation - check park position as indicated.
- The right angle tab on the right hand pivot post is designed to just miss the extension on the right hand link half and serves as a safety device. **Do not remove. Please call if you think you need to modify this part.**

Do not install wiper arms and blades yet

•PARK POSITION CONFIRMATION AND ADJUSTMENT• *(Adjustment is usually not needed)*

We make every effort to adjust the drive arm on the motor so that the unit will park correctly at the end of the stroke. If the wipers park either early (before the end of the travel) or late, review figure 3.

- Turn the motor on and then off to park the motor. (Make a "flag" from masking tape or wire ties on the pivot shafts so you can see the operation of the system.)
- If it is necessary to adjust the park position, use an adjustable wrench to hold the drive arm from turning while loosening the ½" nut securing it to the motor.
- Pry the drive arm loose from the motor shaft taper and rotate it to line up points "A" "B" and "C" as noted in figure 3.
- **Make sure** you keep the drive arm from rotating as you re-tighten the jam nut or the adjustment will be worse than when you started!
- Put the dashboard back together.
- Install wiper arms and blades.

Figure 1 1957 Installation

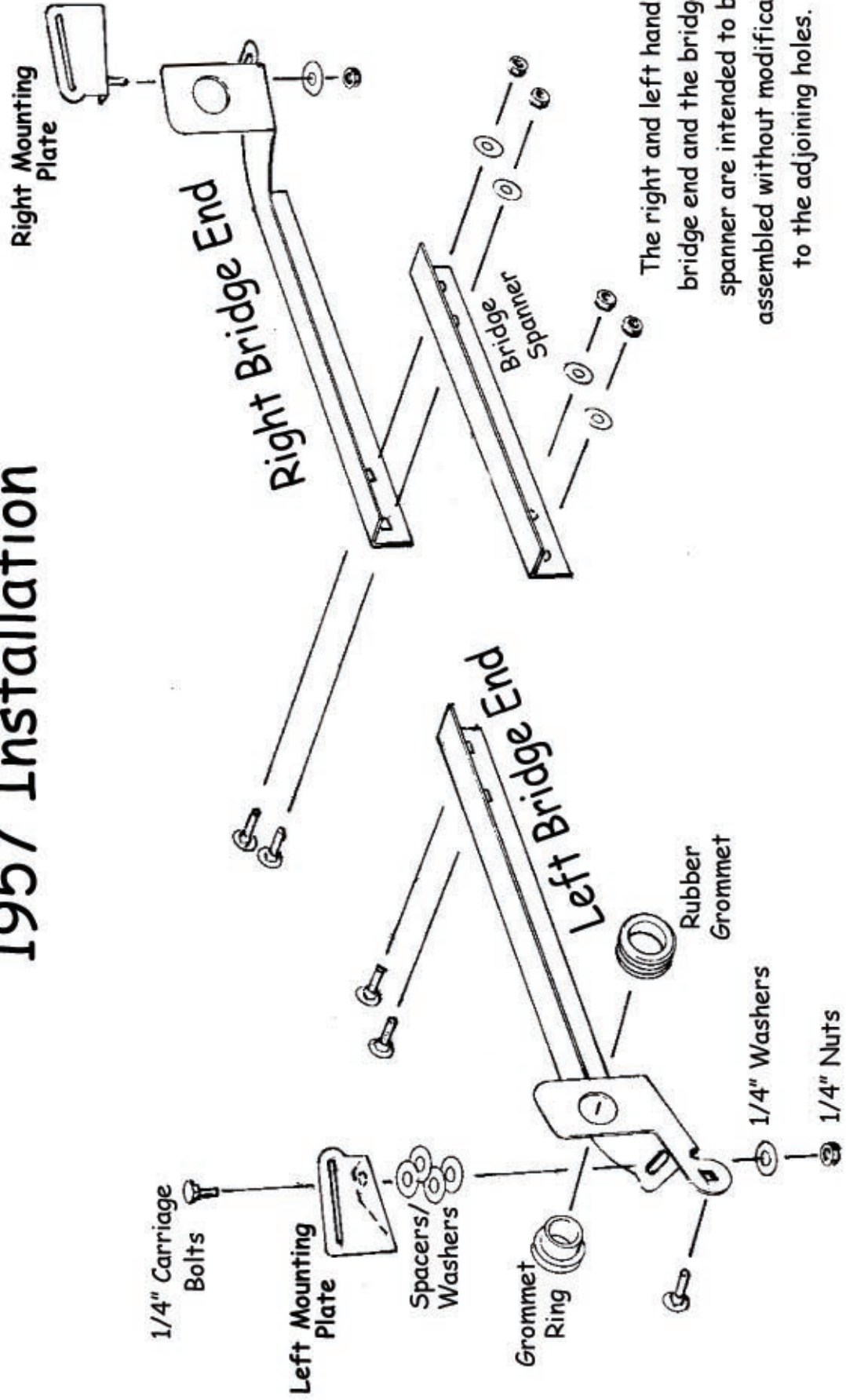

The right and left hand bridge end and the bridge spanner are intended to be assembled without modification to the adjoining holes.

Figure 2 1957 Installation

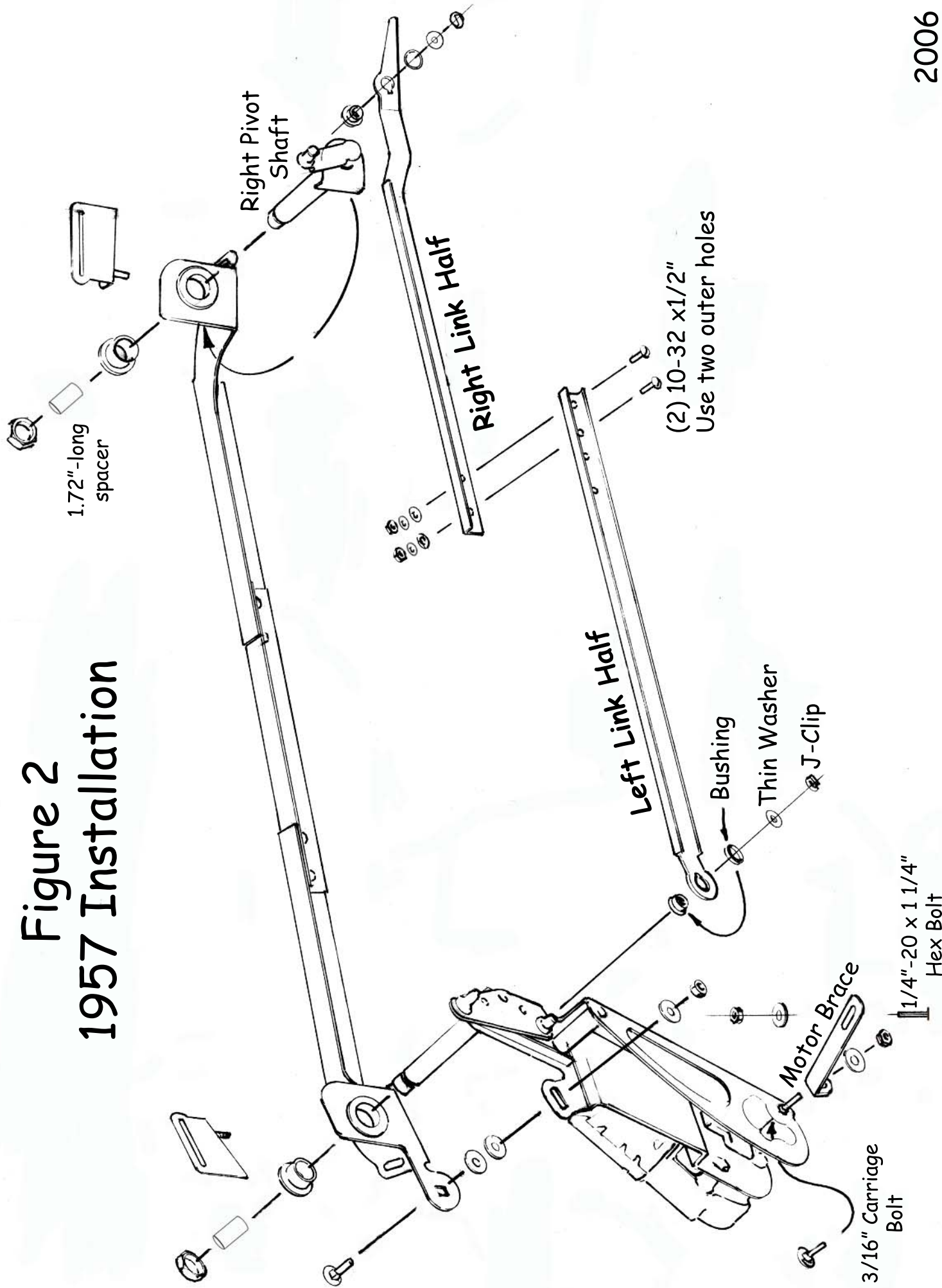

Figure 2A

1957 Installation

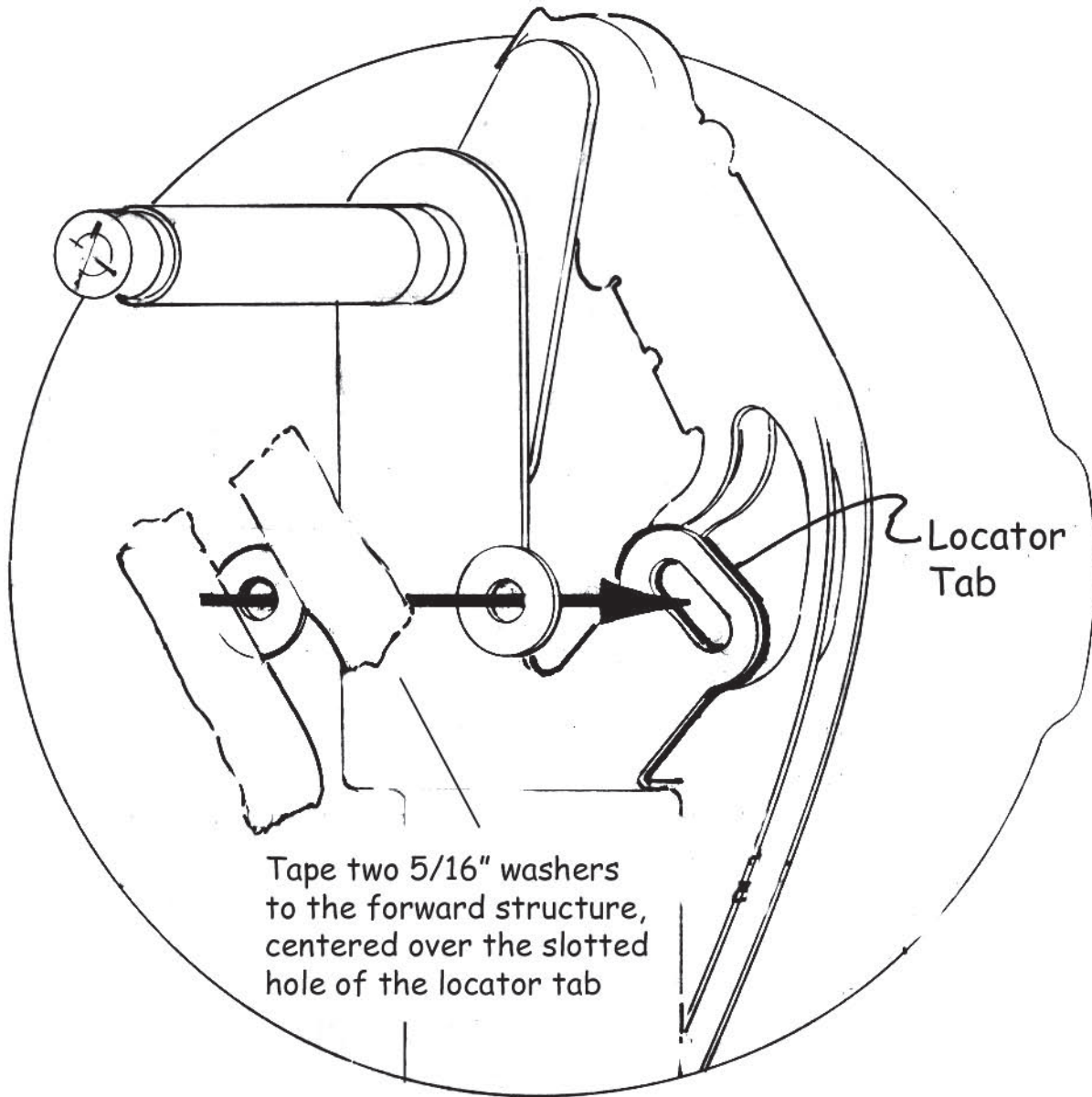

Figure 3

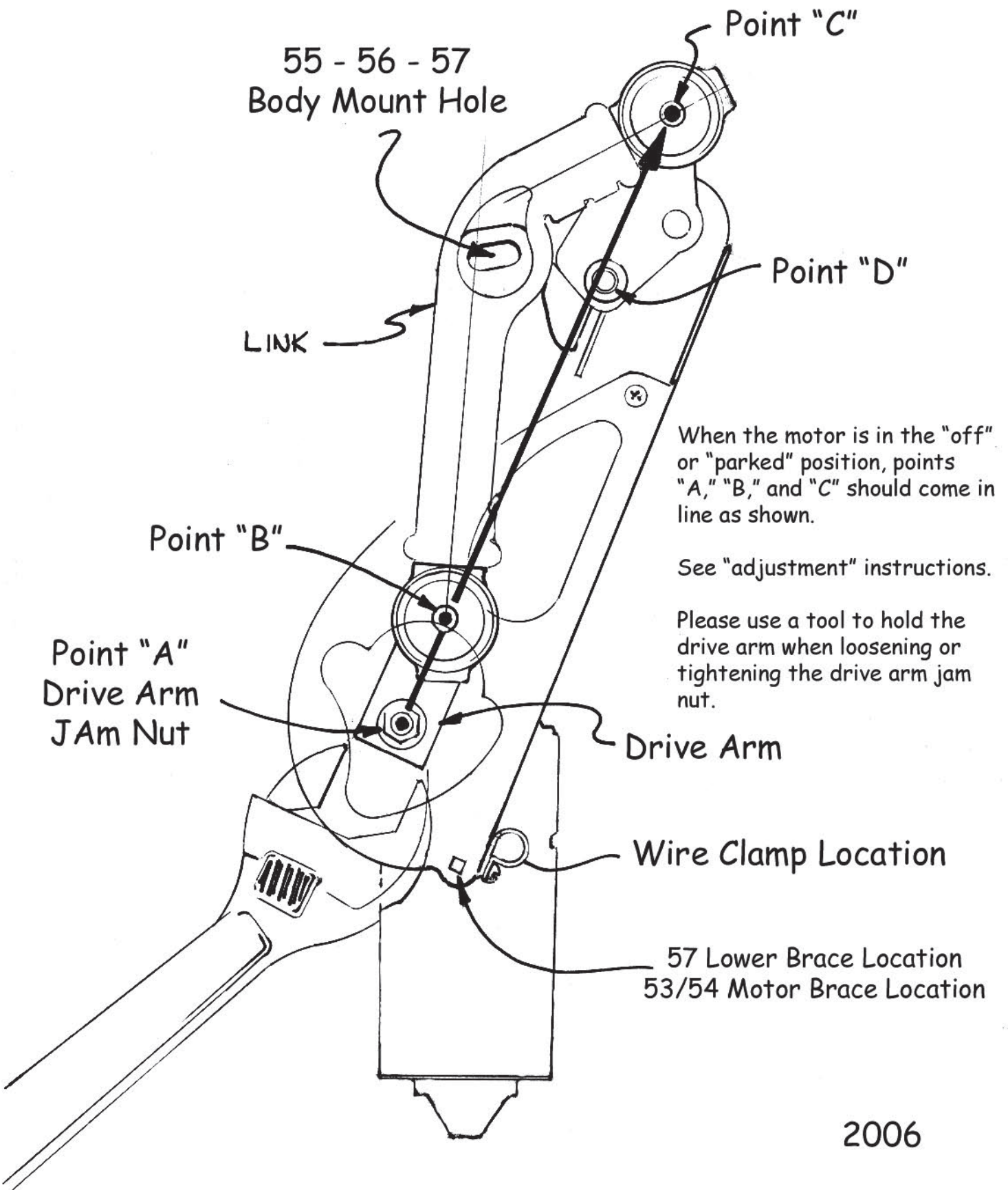

Figure 4 1957 Installation

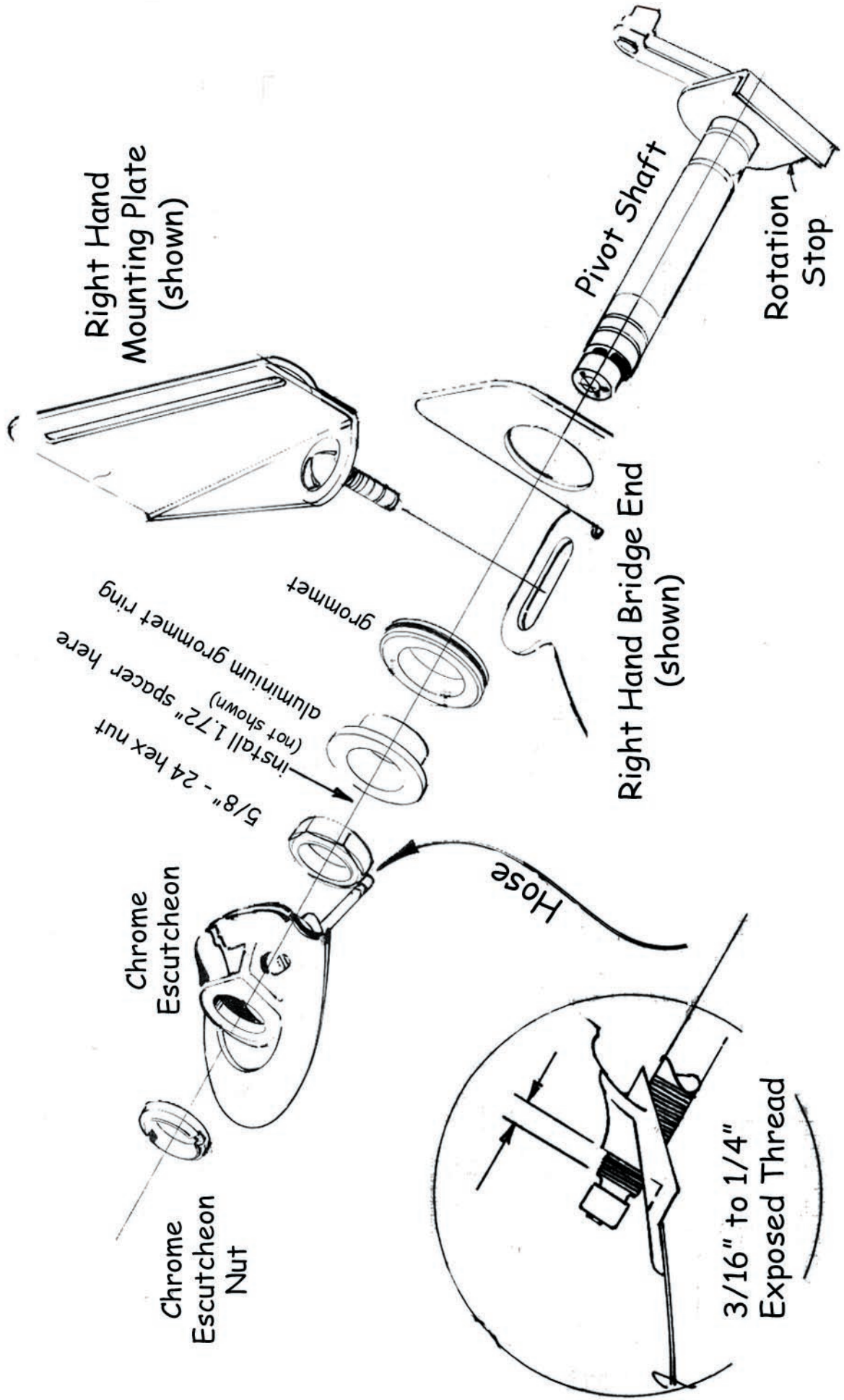
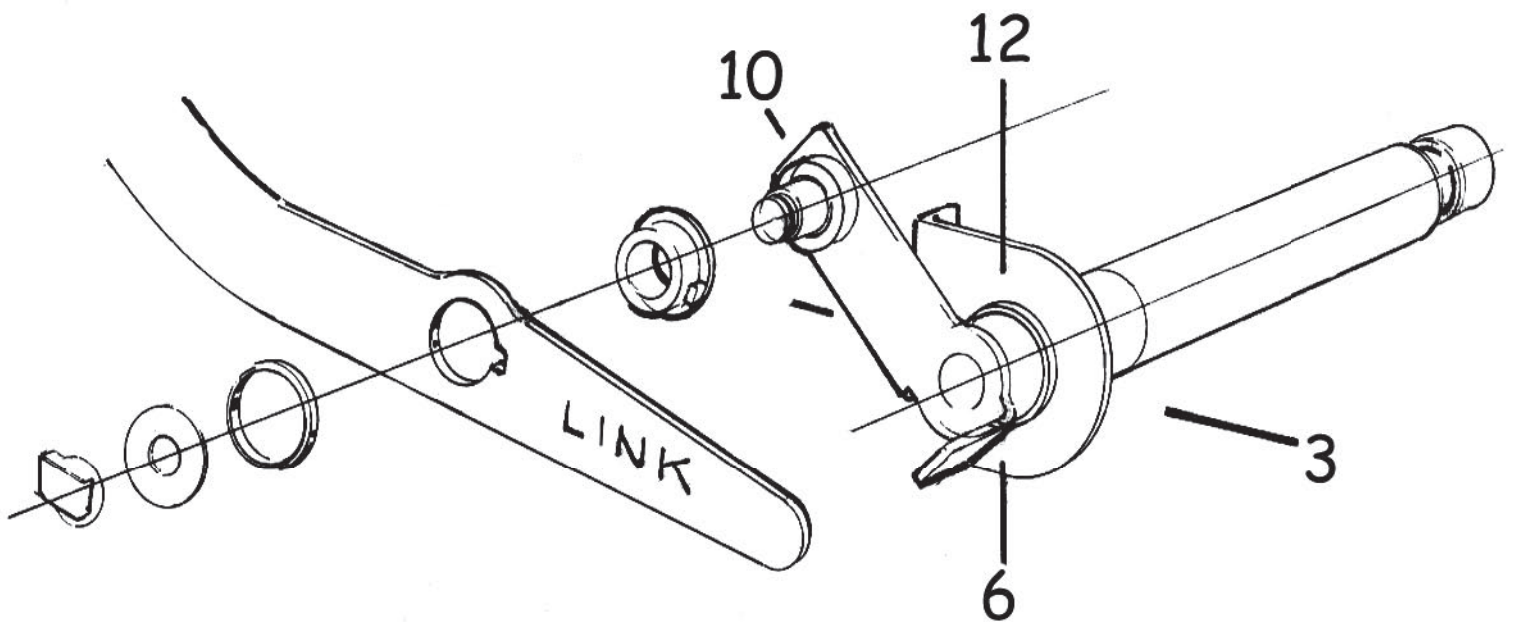

Figure 5

Passenger Side Pivot Shaft



(57 Chevy Shown)

Figure 6

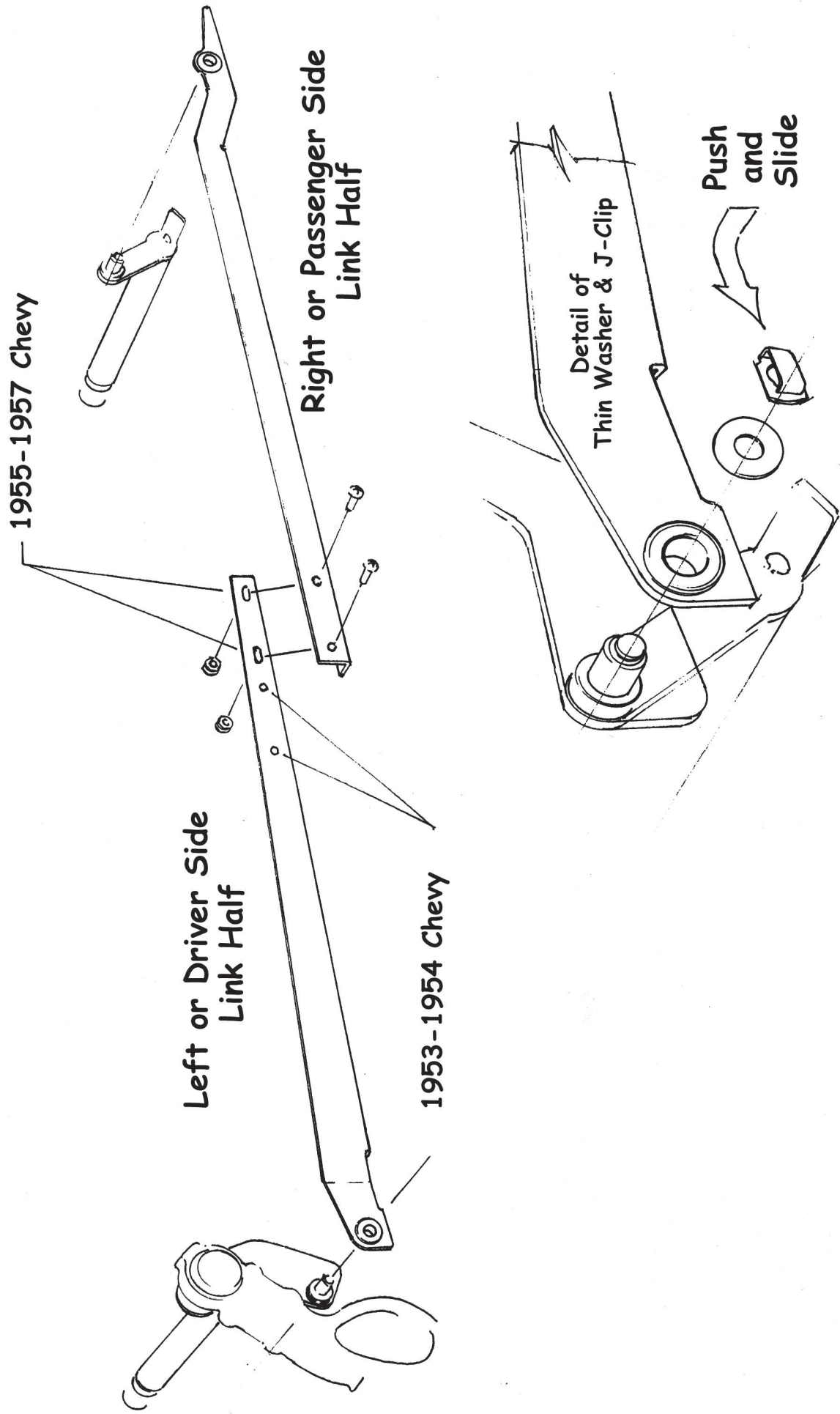

RAINGEAR

2 Speed Switch With Washer

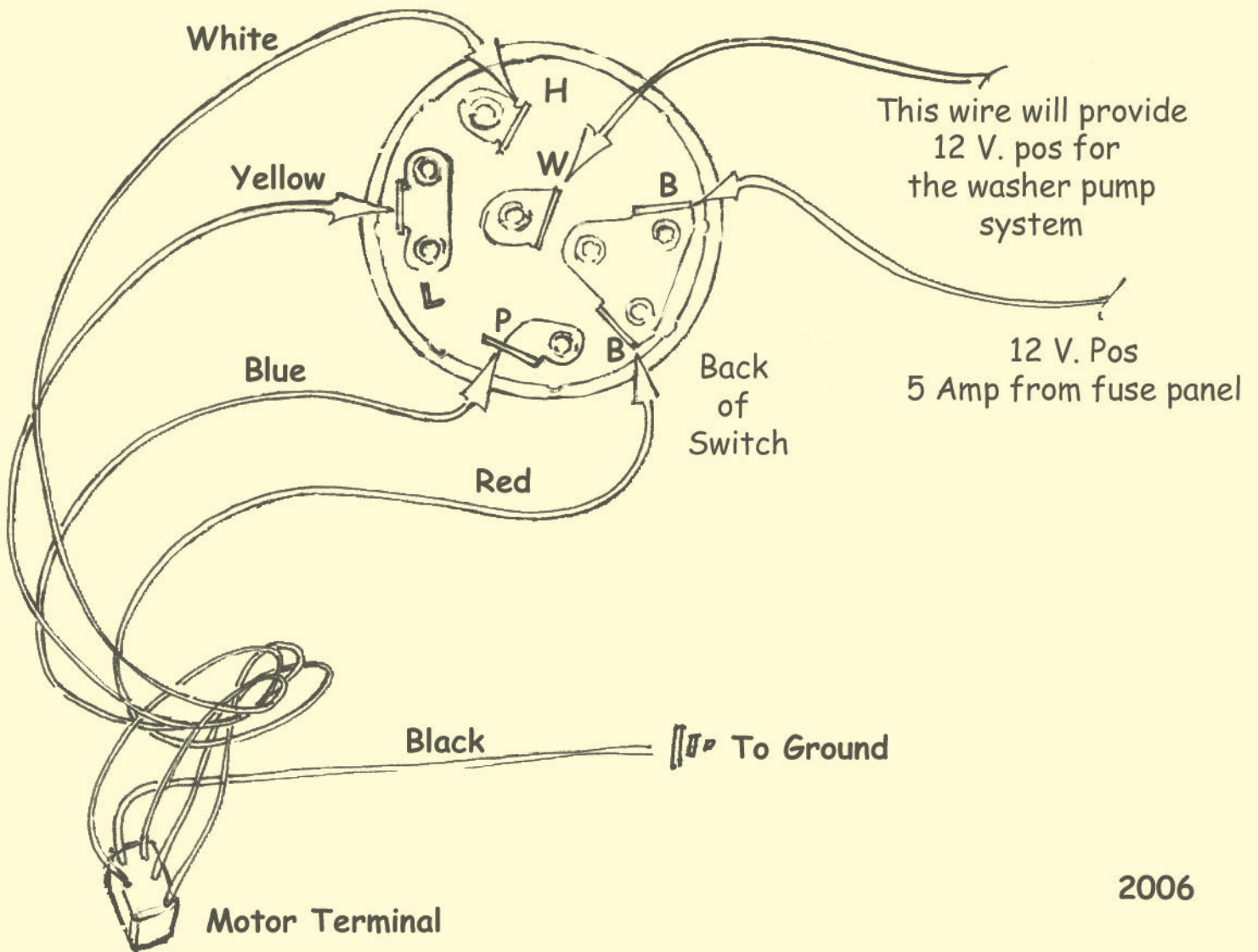
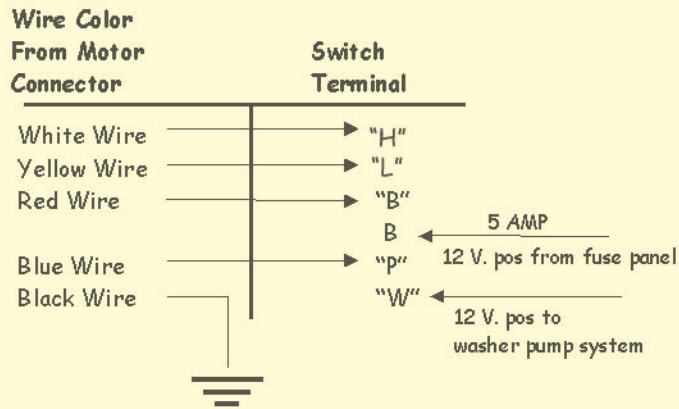

RAINGEAR

2 Speed/Intermittent Switch With Washer

Please Note:
The Intermittent Switch
CANNOT be tested
on a Battery Charger

Turn knob
to adjust the
intermittent
wipe speed

Push knob to
squirt washers -
the wiper blades
will cycle twice

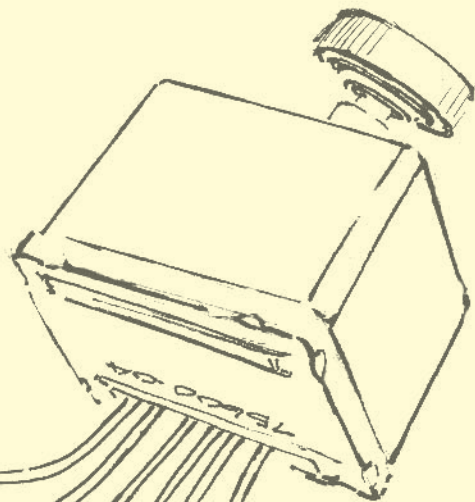

White to White

High

Low

Yellow to Yellow

DELAY SWITCH
MUST
BE GROUNDED



Black

Red

12 Volts, pos
5 amp fuse
from fuse panel

12 Volts, Pos
to Washer Pump System

Brown

If washer pump system is not installed,
this wire end must be covered

Red
to
Red

Blue to Blue

Black wire from motor
connector must
be grounded

Black

